

columbus

Manual sweeper

K 70|40

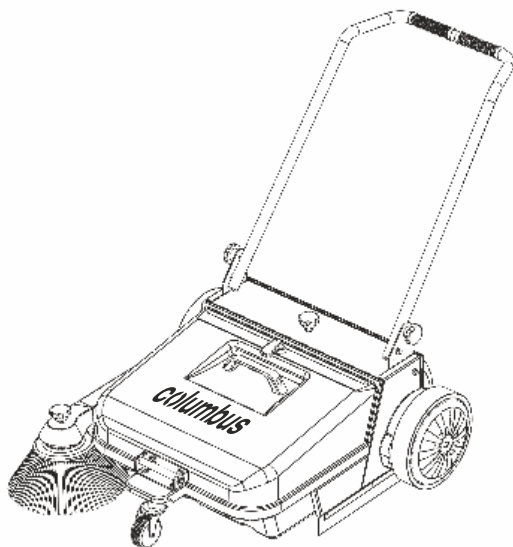

Use and maintenance manual

11.2024

columbus

WARNING :

Do not use the sweeper without reading the "use and maintenance manual".





MANUAL SWEEPER

Congratulations,

you have chosen for your activities the use of a K 70|40 Sweeper, a handy and easily utilizable machine.

The manual sweeper is able to satisfy efficiently all your requirements about cleaning, from the small use to the professional one.

The various range of proposed versions perfectly conforms to every type of utilization.

CONTENTS

SAFETY RULES	3
UNPACKING	4
MARKING AND IDENTIFICATION	4
INSTALLATION	5
USE	6
ADJUSTMENT	7
EMPTYING OF CONTAINERS	8
ROUTINE MAINTENANCE	9
EXTRAORDINARY MAINTENANCE	10
GENERAL INFORMATION	12
TECHNICAL PARTICULARS	13

SAFETY RULES



The manual sweeper is not fit for sweeping substances and materials which are combustible, explosive, toxic, carcinogenic or which present health hazards.

Do not sweep burning or scorching things, such as cigarettes, matches and the like.

When removing glass, metal or other materials from the dirt container, use strong gloves to avoid getting hurt.

The dirt container should be emptied after each use.

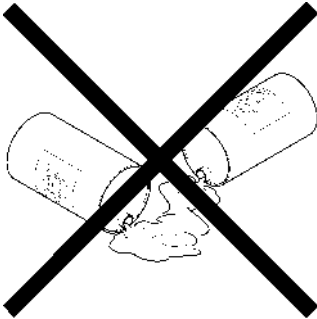

Do not use the sweeper too near sources of heat (fire, radiators, air heaters or other heating equipment).

Use exclusively original spare parts and accessories.

UNPACKING

Unpack the machine carefully and avoid manoeuvres that may cause damages. For reasons of transport and packing dimensions, some accessories may be furnished disassembled.

In this case, assemble them following the instructions of this handbook.

Keep parts of the packing (plastic bags, foam polystyrene, nails, etc.) out of reach of children. They are potential sources of danger.

MARKING AND IDENTIFICATION

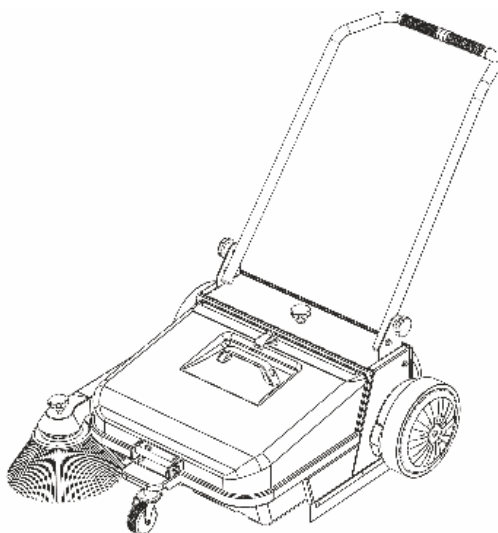

MODELLO	
MATR.	CODE
CE	

INSTALLATION

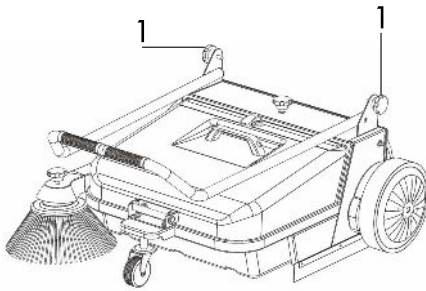

After unpacking the sweeper, install the handle in operating position and the brush on the relative support arm according to the following procedure:

- Unscrew locking wheels (1).

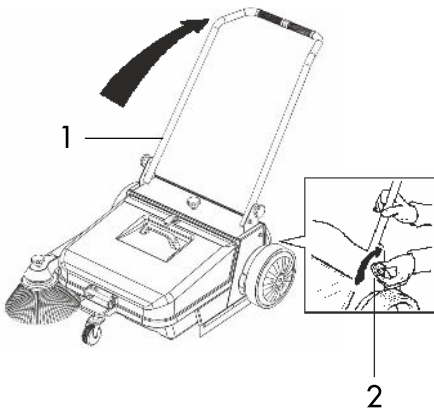

- Lift the handle to the operating position (1).
- Reposition wheels (2). Make sure to tighten them hard in the proper place on the handle.

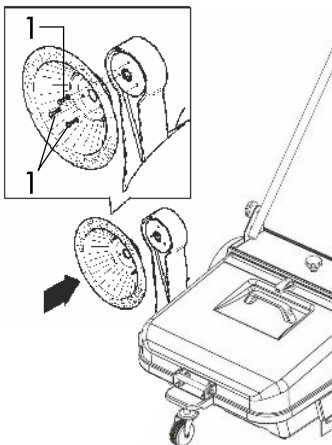

- Take the brush out of the dirt container.
- Lift the support arm to a vertical position.
- Position the brush against the rotary support. Make sure that brush holes and support holes are matching.
- Firmly secure the brush to its support with the screws supplied with the product (1).



USE

Simply push the manual sweeper on the flooring where there is dirt to eliminate.

N.B.: Remember that the number of revolutions of sweeping rolls (thus, efficiency) depends on the speed of travel.

Attention: Strings, wires, packing tapes and objects with similar lengths should be collected by hand. Remove them if they get rolled onto the brushes.

ADJUSTEMENT

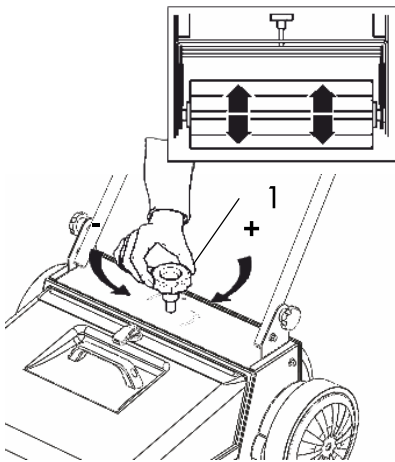

The manual sweeper is factory-adjusted for the operation on plane and smooth ground. Therefore, you only need to bring the lateral brush to the operating position.

As a rule, brushes should be adjusted so as to touch the ground with a light pressure. To adjust the worn main sweeping roll or to use the machine on a non-flat ground, simply rotate the wheel (1) clockwise or counterclockwise to the requested height.

N.B.: A clockwise (+) rotation of the wheel lowers the brush to the floor; a counterclockwise (-) rotation lifts it.

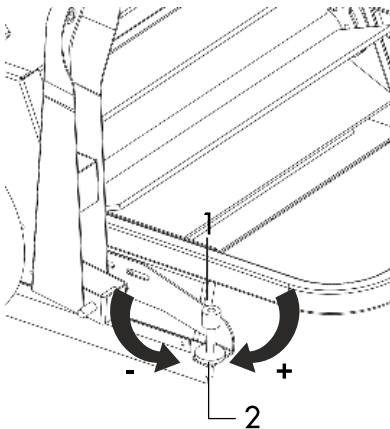

To adjust the lateral brush it's enough to lift it in rest position and, after having unloosed the lock nut (2), turn manually clockwise or counterclockwise the setscrew (1).

N.B.: Like the above-mentioned brush, a clockwise rotation (+) lowers the lateral brush, while a counterclockwise rotation (-) lifts it.

EMPTYING OF CONTAINERS

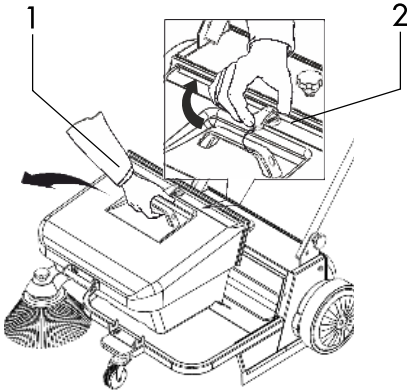

Turn the handwheel (2) counterclockwise to unlock the main basin.

To empty the main container, simply take it by the handle and lift it upwards, withdrawing it from lateral guides (1).

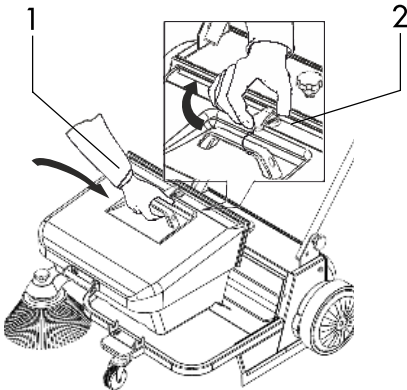

and turn the handwheel (2) clockwise.

ROUTINE MAINTENANCE

This manual sweeper does not require servicing.
Dry clean only.
Do not wash the machine with water or solvents.

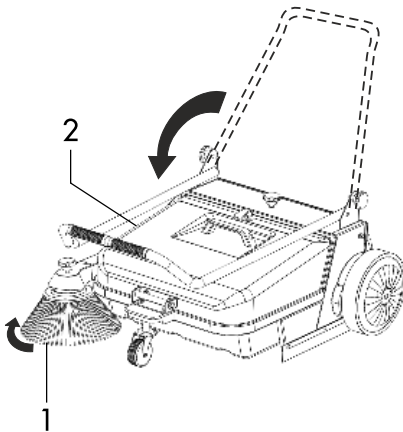

To avoid damaging lateral brush bristles, lift the brush from the ground after every usage of the sweeper (1).

In this way, during rest intervals, bristles are not constantly under pressure and do not lose efficiency in cleaning when used. If it is necessary to put the sweeper in limited spaces, simply unscrew wheels and bend the handle forward to a horizontal position (2).

Tighten wheels and store the product.

EXTRAORDINARY MAINTENANCE

REPLACEMENT OF BRUSHES

Central Brush:

- Remove completely the front basin for wastes;
- Unscrew the two clamping screws (1);
- Extract the central brush (2) as shown in Figure;
- Assembly the new brush following the above-mentioned stages backwards.

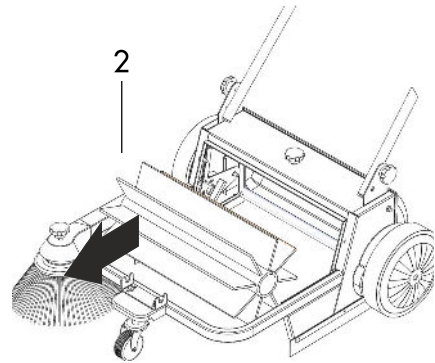
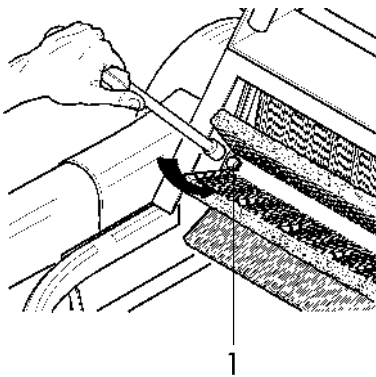

Lateral Brush:

- Lift the brush support arm to a vertical position.
- Unscrew fastening screws (1) and remove the worn brush.
- Reassembly the new brush following the above-mentioned stages backwards.

N.B.: After installing new brushes, check their height. If necessary, adjust them.

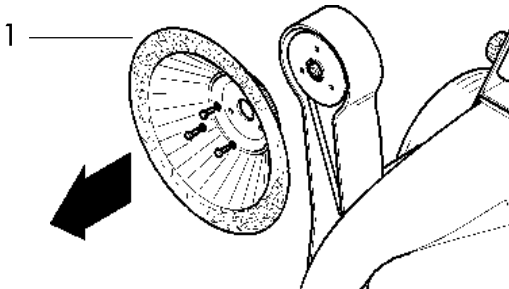

REPLACEMENT OF LATERAL BRUSH BELT

- Lift the lateral brush.
- Remove the lateral brush unloosening the appropriate central lock nut (1).
- Extract the worn belt (2).
- Assemble the new belt following in opposite way the operations previously described.

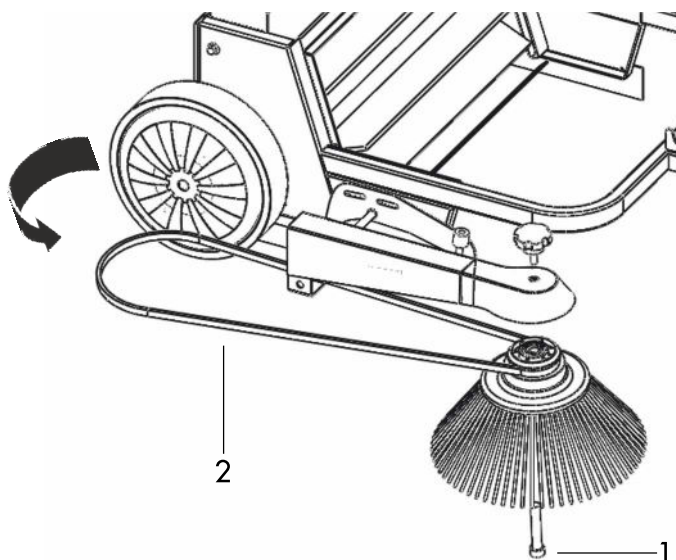



GENERAL INFORMATION

Packing - shipping

Shipping and transport is in cardboard cartons. The packing material is particularly sensitive to rain, fog, direct sunshine, etc.

If the machine has to be transported and the original packing material is not available, the machine must be immobilized to prevent any movement inside the vehicle.

Demolition of the machine

If you decide to scrap the machine, it's recommended to empty the various inner basins from the products contained inside them.

Ecological information

The environment must be respected when you want to get rid of packing materials, the various liquids, spare parts, or the whole machine.

The current laws must be followed, in order not to poison earth, water and air.

Instructions for proper treatment of waste

- Ferrous materials, aluminium, copper: these metals can be recycled and given to a special authorized collecting center.
- Plastic materials: they must be taken to a dump, an incinerator, or a special recycling center.
- Used oils: they must be taken to a special authorized collecting center.



TECHNICAL PARTICULARS

MODEL	K 70 40
ADVANCE	MANUAL THRUSTING
FRAME	STEEL
CAPACITY OF WASTE COLLECTING BASIN	40 lt
CENTRAL BRUSH	ADJUSTABLE
LATERAL BRUSH	ADJUSTABLE
WHEELS	RUBBER MADE
WEIGHT	25 kg



NOTES



NOTES

Dealer's signature and stamp



We reserve the right to effect modifications within the framework of technical progress !

Columbus Cleaning Machines Private Limited

A304 Poonam Chambers,
Byramji Town, Nagpur, 440013
Telefon +91 - 7888077011

info@columbus-clean.in
www.columbus-clean.com/in

columbus